

Leister FUSION 2 / 3C / 3 Hand-Extruder



Please read operating instructions carefully before use and keep for further reference.

APPLICATION

Welding PE and PP thermoplastics for applications in

- container engineering
- plastic fabrication
- pipeline construction
- landfill sites and abandoned polluted areas

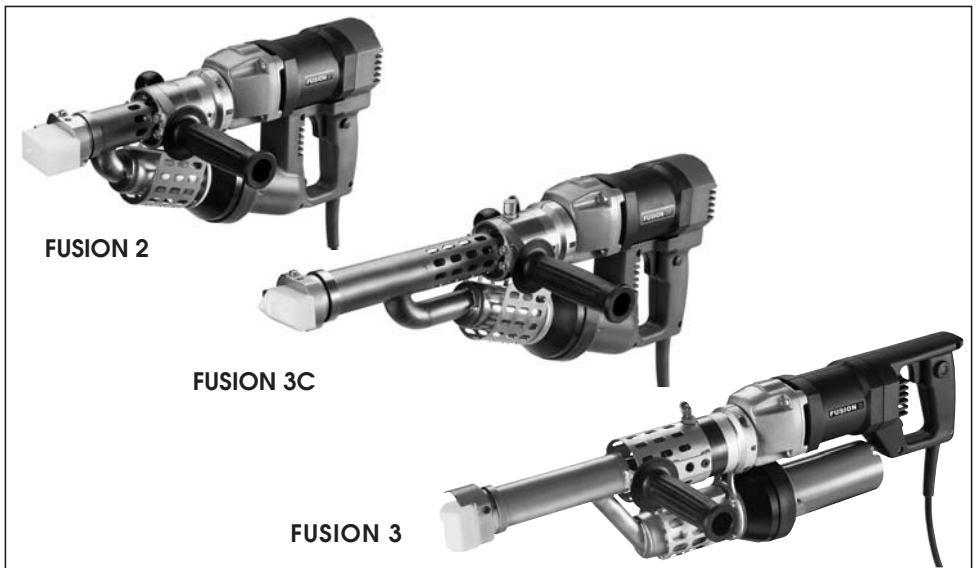



WARNING



DANGER! Danger when opening up the tool, as live components and connections are exposed. Therefore, before opening the tool, unplug it to ensure disconnection from the mains.



Incorrect use of the hand extruder (e.g. overheating of the material) can present a **fire and explosion hazard**, especially near combustible materials and explosive gases.



Danger of getting burned! Do not touch exposed hot metal parts and escaping plastized material. Let the tool cool down. Do not point the hot air flow and the escaping plastized material in the direction of people or animals.



CAUTION



The **voltage rating** stated on the name plate of the tool must correspond to the mains voltage and frequency.



For personal protection on building sites we **strongly recommend** the tool be connected to a **RCCB (Residual Current Circuit Breaker)**.



The tool must be operated **with supervision**. Heat can reach combustible materials, which are out of sight.



Protect tool from **dampness** and **wet**.

TECHNICAL DATA		FUSION 2	FUSION 3C	FUSION 3
Voltage	V~	230	230	230
Power consumption	W	2800	2800	3500
Frequency	Hz	50/60	50/60	50/60
Air flow (20°C)	l/min	ca. 300	ca. 300	ca. 300
Air temperature	°C	max. 340	max. 350	max. 350
Plasticizer temperature	°C	max. 300	max. 320	max. 320
Welding output * Ø 3 kg/h			PE 1.6–2.3 PP 1.3–2.0	PE 1.6–2.3 PP 1.3–2.0
Welding output * Ø 4 kg/h		PE 1.3–1.8 PP 1.3–1.8	PE 2.0–3.5 PP 1.5–2.7	PE 2.0–3.5 PP 1.5–2.7
(* Average values at 50 Hz)				
Welding rod	mm	Ø 4 ± 0.2 <small>(in accordance with DVS 2211)</small>	Ø 3 / Ø 4 ± 0.2 <small>(in accordance with DVS 2211)</small>	Ø 3 / Ø 4 ± 0.2 <small>(in accordance with DVS 2211)</small>
Size L × W × H (without welding shoe)	mm	450 × 98 × 225	588 × 98 × 225	690 × 98 × 187
Weight	kg	5.9 with 3 m cable	6.9 with 3 m cable	7.2 with 3 m cable
Mark of conformity		CE	CE	CE
Mark of approval		Ⓢ	Ⓢ	Ⓢ
Certification scheme		CCA	CCA	CCA
Protection class II		□	□	□

Line/mains voltage cannot be switched over

Description of tool

- | | |
|--|--------------------|
| 1. Hot air blower switch | 9. Handle |
| 2. Air temperature potentiometer | 10. Tool handle |
| 3. Locking device drive on/off switch | 11. Drive unit |
| 4. Drive on/off switch | 12. Hot air blower |
| 5. Welding shoe | 13. Mains cable |
| 6. Welding rod opening | 14. Air slide |
| 7. Extrusion rate regulation potentiometer | 15. Air inlet |
| 8. Tool rest | 16. Air hose |

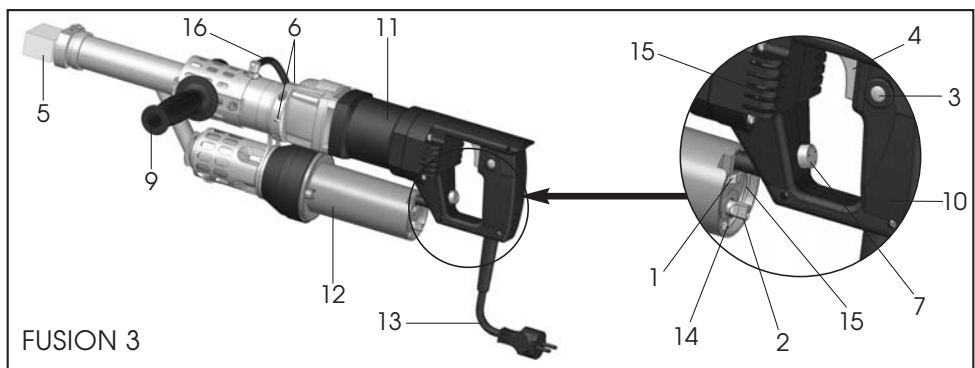
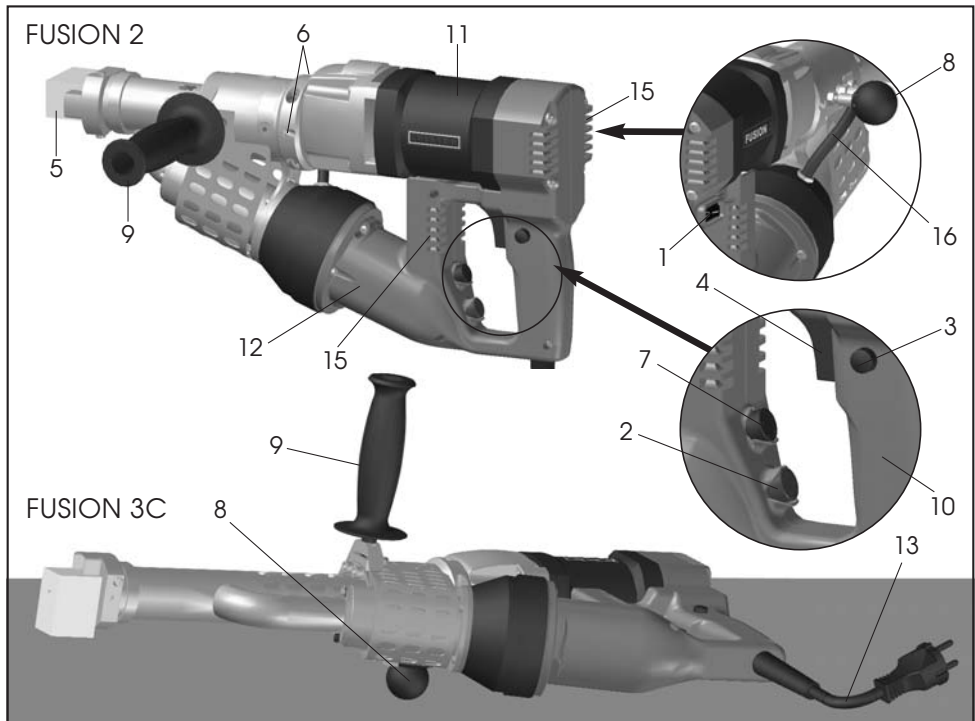

Preparation for welding

- The **tool rest (8)** or **handle (9)** can alternatively be mounted left of right of the tool.
- When using an extension cable, take care to ensure the minimum cable cross-section:

Length (m)	Minimum cross-section (at ~230V) (mm ²)
up to 19	2.5
20-50	4.0

Extension cables must be approved for the place of work (e.g. outdoors) and labelled accordingly.

- If a generator is used to supply electricity, the rated power of the generator must be 2x the rated power of the hand extruder.



The hand extruder must not be operated in inflammable environments or where explosion hazards exist. Ensure stable positioning during operation. The connecting cable and the welding rod must remain unimpeded and must not hinder the user or others during operation.

Switching on

- Connect the hand extruder to the mains supply.
- Switch on the tool at the **hot air blower switch (1)**.
- Adjust the hot air temperature at the **air temperature potentiometer (2)**.
- The operating temperature is reached after approximately 10 minutes.

Starting protection

The tool is equipped with current overload protection. The drive switches off automatically if current consumption is too high. The drive can for example not be started, or only for a brief time, if the material in the screw is insufficiently plastized.

Overheating protection

If the drive overheats as a result of external influences or if the melting temperature of the material in the screw is too low, the internal temperature protection switches off the drive. The overheating protection switches on again automatically once the drive has cooled down.

Starting the welding process

- Fit the required **welding shoe (5)** according to the paragraph "Change of welding shoe" (see page 6).
- Welding can begin once the operating temperature has been attained. Operate the **drive on/off switch (4)** for this purpose. Operate the tool only when feeding welding rod.
- Feed welding rod of 3 or 4 mm diameter into the **welding rod opening (6)** and allow a small amount plastized material to escape.



- **CAUTION! Never feed welding rod into both welding rod openings at the same time!** (see "Starting protection").
- **The welding rod fed must therefore be clean and dry.**

- The extrusion rate can be changed using the **extrusion rate regulation potentiometer (7)** dependent on the seam geometry and the choice of material.
- Interrupt material extrusion using the **drive on/off switch (4)**.
- Direct the **pre-heating nozzle (21)** to the welding zone.
- Pre-warm the welding zone with back and forth movements.
- Position the tool on the prepared welding zone and operate the **drive on/off switch (4)**.
- Carry out test welding and analyse.
- Adjust the hot air temperature using the **air temperature potentiometer (2)** and the extrusion rate with the **extrusion rate regulation potentiometer (7)** as required.
- In case of a prolonged welding process, the **drive on/off switch (4)** can be held in the active state with the **locking device (3)**.
- The welding rod is pulled in through the **welding rod opening (6)** automatically after starting. The welding rod pull - in must not be impeded.

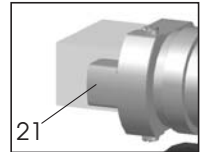

Switching off

- Release the **locking device (3)** by briefly pressing the **drive on/off switch (4)** and then letting go. Remove welding material from the welding shoe in order to avoid damage on the welding shoe when starting the next time.
- The tool must only be laid down on the **tool rest (8)** (see pg. 3, centre fig.).



- **Use a fireproof base.**
- **The hot air jet must not be directed towards persons and objects.**

- Adjust the **air temperature potentiometer (2)** to "0". Let the tool cool down.
- Switch off at the **hot air blower switch (1)**.

Checking the temperature of the extruded material and the pre-heating temperature

- The temperatures of the extruded material and the hot air jet are to be checked at regular intervals when carrying out welding work over an extended period: Fast display electronic temperature measuring devices with the appropriate temperature probes have to be used. The highest temperature in the hot air jet between the nozzle outlet plane and a depth of 5 mm is to be determined. The measurement probe must be inserted in the welding shoe in the middle of the extruded material to measure its temperature.

Change of welding shoe

- The welding shoe must only be changed when the tool has attained its operating temperature. Work with temperature resistant gloves only.



Danger of getting burned!

- Switch off the hot tool and disconnect it from the mains supply.
- Remove the **welding shoe holder (17)** by loosening the **set screws for the welding shoe holder (18)** from the **extruder nozzle (19)**.
- Clean the **extruder nozzle (19)** each time the welding shoe is replaced and remove any welding deposits.
- Attach an appropriate **welding shoe holder (17)**.
- The pointing of the **welding shoe (5)** (tool angle to the welding seam) can be chosen freely.
- The **welding shoe (5)** can be taken off the **welding shoe holder (17)** by loosening the **set screws for the welding shoe (20)** (e.g. for reworking).

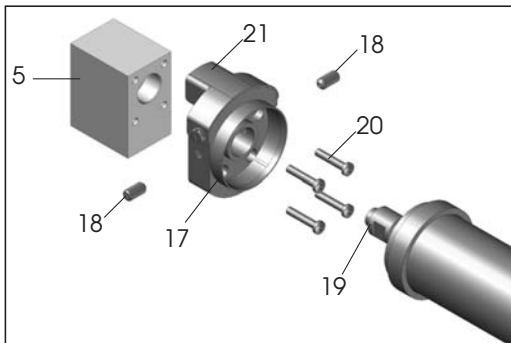

Detail welding shoe

- 5. Welding shoe
- 17. Welding shoe holder
- 18. Set screw for welding shoe holder
- 19. Extruder nozzle
- 20. Set screw for welding shoe
- 21. Pre - heating nozzle

ACCESSORIES

- Only Leister accessories must be used.

MAINTENANCE

- In case of soiling clean the **air inlet (15)** on the hot air blower with a brush.
- Clean the **extruder nozzle (19)** each time the welding shoe is replaced and remove any welding deposits (see page 6).
- Check power supply cord and plug for electrical and mechanical damage.
- Regularly clean the **air hose (16)**.

SERVICE AND REPAIRS

- Have the state of the carbon brushes of the drive and hot air blower checked by your service centre after ca. 250 hours of operation. The drive and the hot air blower switch off automatically once the minimum carbon length has been reached.

Operating time; Drive ca. 300 hours (brushes)

Hot air blowers ca. 1000 hours (brushes)

- Repairs should only be carried out by authorized **Leister Service Centres**. They guarantee a specialised and reliable **Repair Service within 24 hours** using original spare parts in accordance with the circuit diagram and spare parts list.

GUARANTEE AND LIABILITY

- Guarantee and liability are in accordance with the guarantee certificate as well as with the currently valid general conditions of business and terms of delivery.
- Leister Process Technologies rejects any guarantee claims for tools which are not in their original condition. The tools must never be altered or changed.

Technical data and specifications are subject to change without prior notice.

Your authorized Service Centre is:

Service Record Leister FUSION 2 / 3C / 3

This document should be kept up to date during repair or servicing by the authorized Leister Service Centre. This document should be in the possession of the owner of the equipment.

Technical data

Order No.

Serial No.

Rated voltage **V**

Rated capacity **W**

Sale **date**

Service

1. Date Service Centre Signature
2. Date Service Centre Signature
3. Date Service Centre Signature
4. Date Service Centre Signature
5. Date Service Centre Signature
6. Date Service Centre Signature

Repair

1. Date Service Centre Signature
2. Date Service Centre Signature
3. Date Service Centre Signature

