

Leister LHS SYSTEM Air Heater



Please read operating instructions carefully before use and keep for further reference.

APPLICATION

The Leister Air Heater type LHS SYSTEM are suitable for building into machines, installations or appliances and are designed for continuous operation.

- **Drying and heating processes** of various types.
- **Shrinking and welding** packaging films and moulded parts.
- **Heating** conveyor ovens or heat tunnels.
- **Activating and loosening** solvent free adhesives and melt adhesives.
- **Sterilizing** packaging materials such as bottles, corks and containers.
- **Separating and fusing** synthetic fibres and fabrics.
- **Soldering processes** on thin metal parts.
- **Speeding up** mixing processes and **dissolving** foams which can arise during mixing and filling operations.
- **Welding** thermoplastic materials.
- **Removing** plastic mould flash.
- Putting a **shine** on plastic surfaces.



LHS SYSTEM 20S
LHS SYSTEM 20L



LHS SYSTEM 40S
LHS SYSTEM 40L



LHS SYSTEM 60S
LHS SYSTEM 60L



WARNING



Danger! When opening up the tool, live components and connections are exposed. The mains plug must be removed from the main socket before opening up the tool. **Caution separate source voltage.**



Incorrect installation and use of air heaters can present a **fire and explosion hazard**, particularly in the proximity of flammable materials and explosive gases.



Do not touch the element housing and nozzle when hot as they can cause **burns**. Do not point the hot air flow at people or animals.



CAUTION



The **voltage rating** stated on the tool should correspond to the mains voltage. IEC/EN 61000-3-11; $Z_{max} = 0.047\Omega + j 0.029\Omega$. If necessary, consultate supply authority.



The tool with protection class I should be earthed using a protective conductor.



The tool must be operated **with supervision**. Warmth can reach combustible materials, which are out of sight.



Protect the tool from **dampness** and **wet**.

Technical Data LHS SYSTEM	20S	20L	40S	40L	60S	60L
Voltage V~	100–230	200–230	100–230	3x230–3x440	3x230–3x480	3x230–3x480
Frequency Hz	50/60	50/60	50/60	50/60	50/60	50/60
Power consumption kW	1.0 / 2.0	3.3	2.0 / 4.0	2.0 / 4.0	4.0 / 6.0	5.0–16.0
Air flow l/min.	min. 100	min. 200	min. 200	min. 200	min. 300	min. 400
Temperature °C	max. 650	max. 650	max. 650	max. 650	max. 650	max. 650
Ambient temperature °C	<65	<65	<65	<65	<65	<65
Weight kg	0.55	0.65	0.85	0.95	3.15	3.65
Size mm	237x97x92	267x97x92	246x112x103	276x112x103	379x116x137	379x116x137
Mark of conformity	CE	CE	CE	CE	CE	CE
Mark of approval	Ⓢ	Ⓢ	Ⓢ	Ⓢ	Ⓢ	Ⓢ
Certification scheme	CCA	CCA	CCA	CCA	CCA	CCA
Protection class I					Ⓢ	Ⓢ
Protection class II	□	□	□	□		

Installation

- When installing the tool, ensure that:
 - only cold air is supplied
 - no (hot air) back pressure develops
 - the tool is not subjected to a hot air flow from another tool
- The tool is protected against mechanical vibration and shaking.
- Installation dimensions on pages 5, 6 and 7.

Air supply

- To protect the tool and the heat element, the stipulated minimum air flow must under no circumstances fall short, and the maximum temperature (measured at the hottest point 3 mm in front of the element housing) must also not be exceeded. In the event that the minimum air flow falls short, the power must immediately be disconnected.
- The air heater should only be supplied with air up to a max. 80°C.
- Pay attention to the direction of the airflow.
- Leister blowers must be used for the air supply (pay attention to the direction of rotation and the electrical connection).
- For use in a dusty environment the tool should be fitted with a Leister stainless steel filter on the air intake connection. Where a particularly critical dust problem exists (eg metal, electrically charged or damp dust) special filters must be used to avoid short circuiting of the tool.

Operation

- The tool must be connected by a qualified electrician in accordance with the circuit diagram (Pages 5,6 or 7).
- Fit a nozzle appropriate to the use.
- It should be checked that the hot air can flow out freely, otherwise a back pressure of hot air may damage the tool (danger of fire!).
- Attention: Keep to the minimum air flow according to the technical details (Page 2).
- Switch on mains.
- Allow the tool to cool down after use.

Attention: Never operate tool without air supply!

Function: Heat element protection

If the heat element overheats, the power supply to the heat element is cut off and the alarm relay function contact opens.

Function: Tool protection

If the tool overheats (air supply too warm or a build up of heat), the power supply for the heat element is cut off and the alarm relay function contact opens.

Measures to be taken if the heating element or tool protection cuts out

- Remove tool from the mains (after 10 seconds the electronics reset automatically).
- Check air supply.
- Check air volume.
- Check air flow.
- Re-connect tool to the mains.

TOOL DESCRIPTION

Leister LHS SYSTEM

1. Screw type cable fitting
2. Air intake connection
3. Power unit
4. Fitting plate
5. Element housing
6. Potentiometer for temperature setting
7. Control unit
8. Control connection

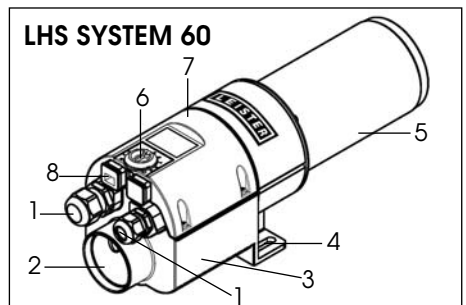
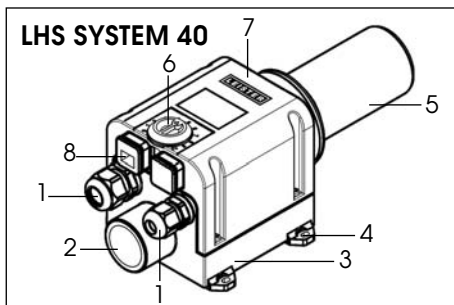
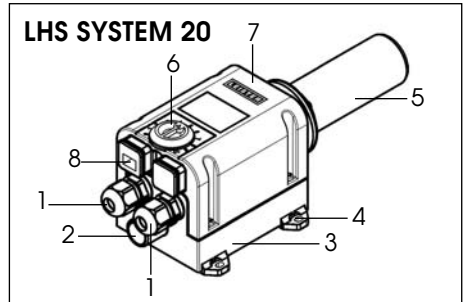

Power unit wiring diagram

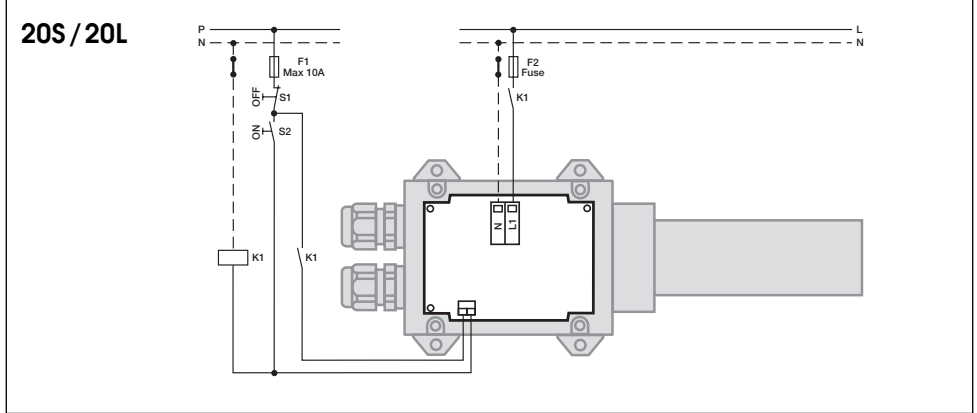

Installation dimensions in mm

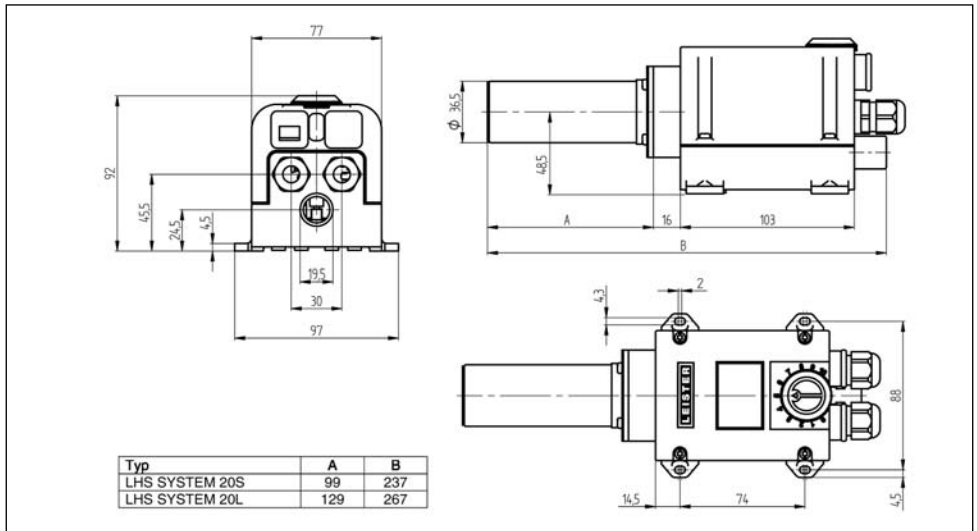

Power unit wiring diagram

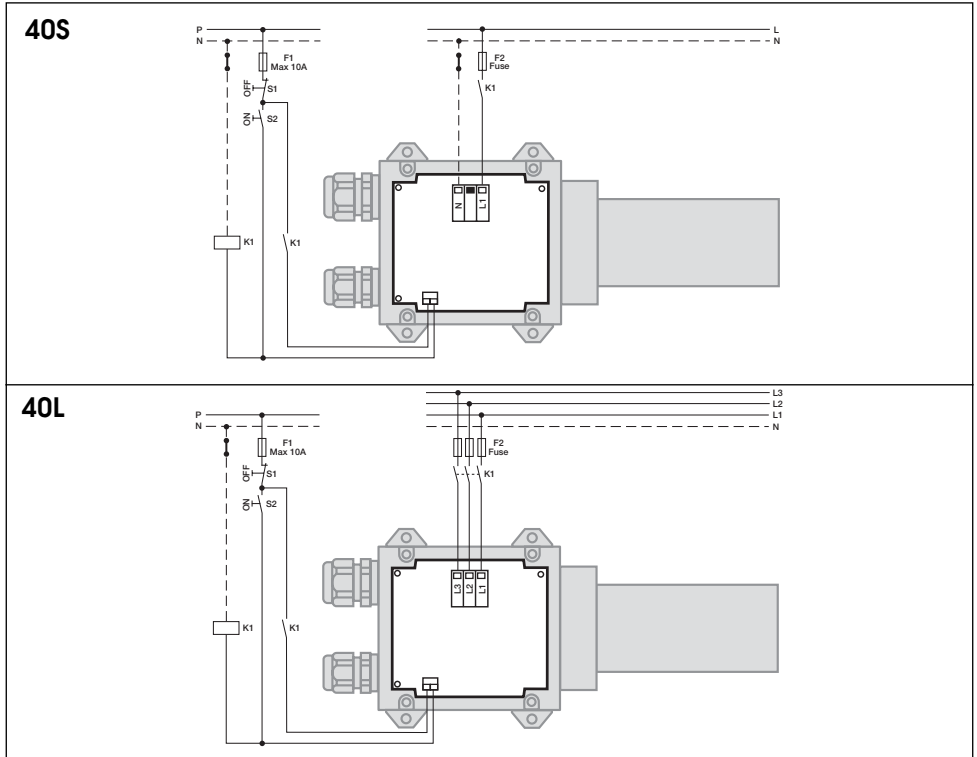

Installation dimensions in mm

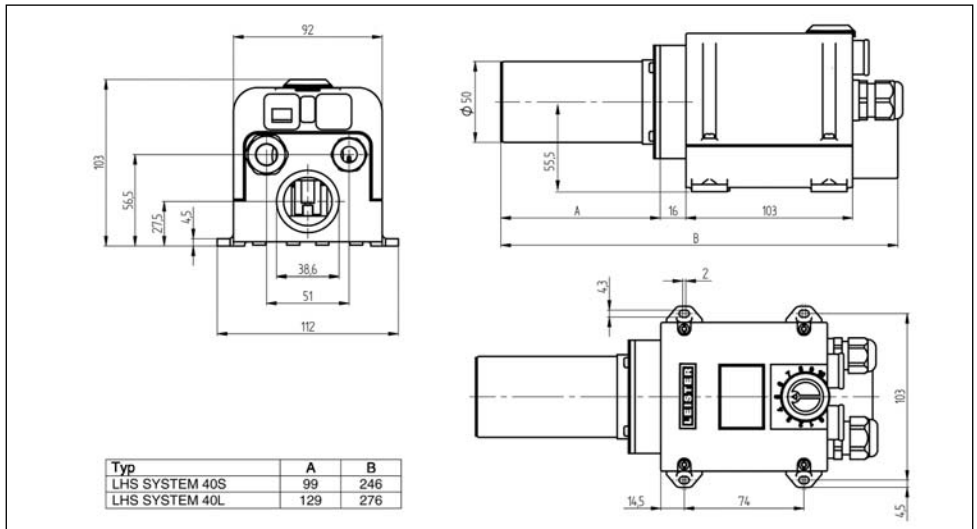

Power unit wiring diagram

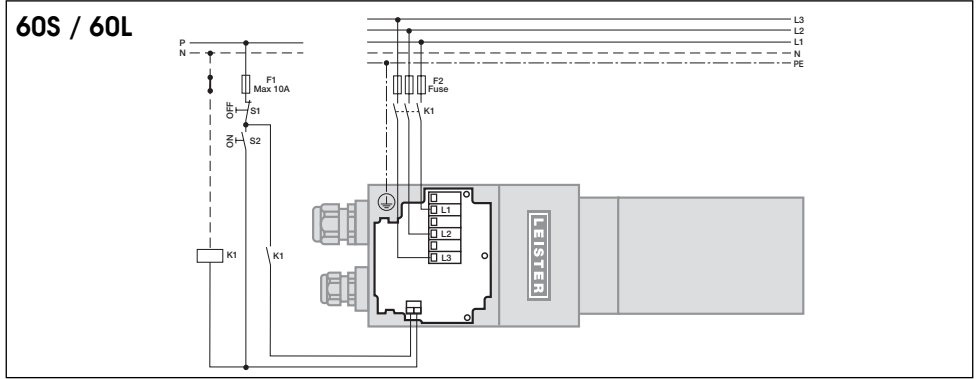

Installation dimensions in mm

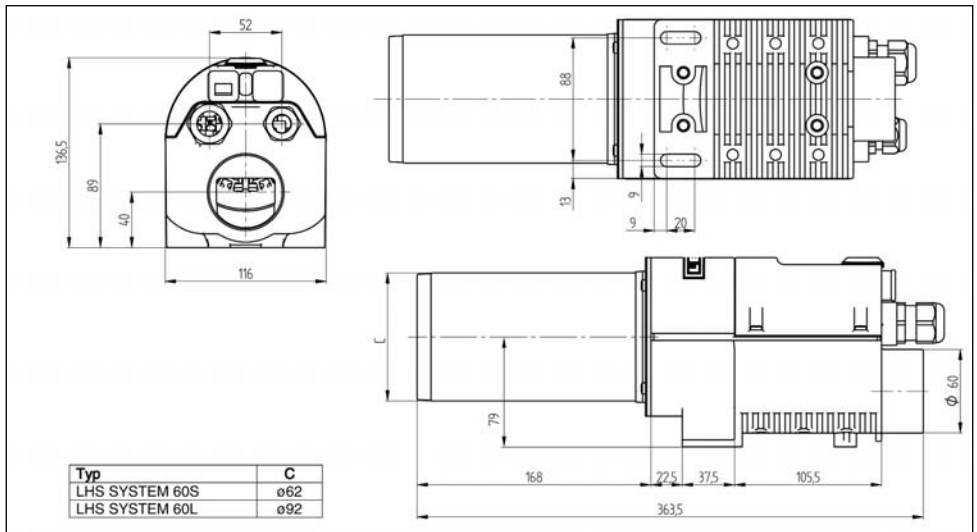

Control unit wiring diagram

20S / 20L, 40S / 40L, 60S / 60L

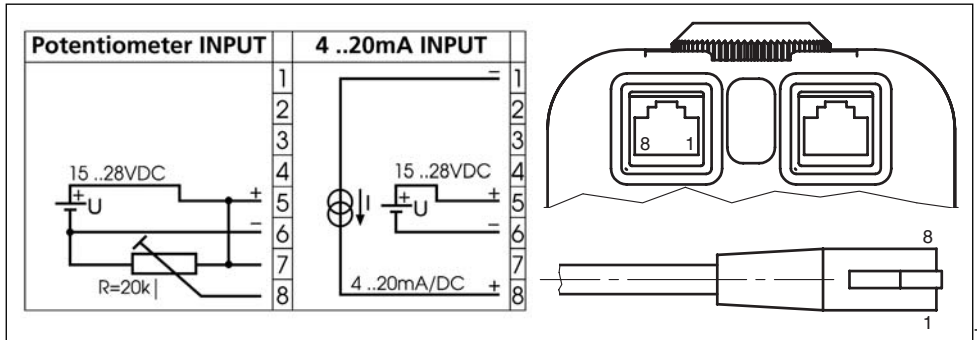

TRAINING

Leister Process Technologies and its authorised Service Centres offer free of charge courses in the range of applications on page 1.

ACCESSORIES

- Only Leister accessories should be used.

SERVICE AND REPAIR

- Repairs should only be carried out by authorised **Leister Service Centres**. They guarantee a correct and reliable **repair service within 24 hours** using original spare parts in accordance with the circuit diagrams and spare parts lists.

WARRANTY

- For this tool, we generally provide a warranty of one (1) year from the date of purchase (verified by invoice or delivery document). Damage that has occurred will be corrected by replacement or repair. Heating elements are excluded from this warranty.
- Additional claims shall be excluded, subject to statutory regulations.
- Damage caused by normal wear, overloading or improper handling is excluded from the guarantee.
- Guarantee claims will be rejected for tools that have been altered or changed by the purchaser.

Technical data and specifications are subject to change without prior notice.

Your authorized Service Centre is: