

A

B

C

D

1

2

3

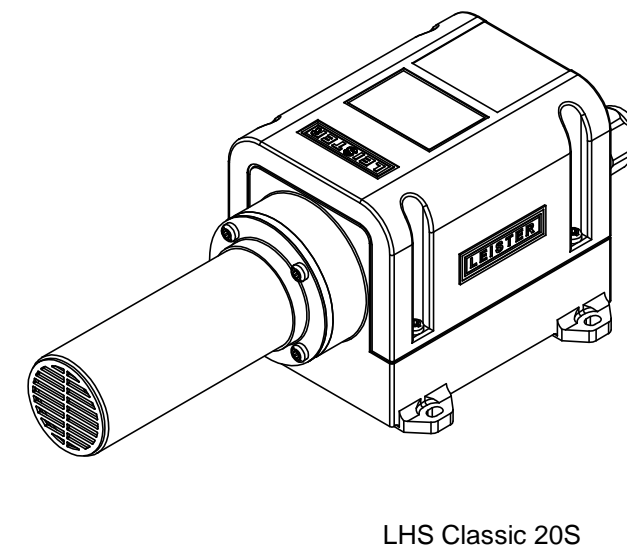
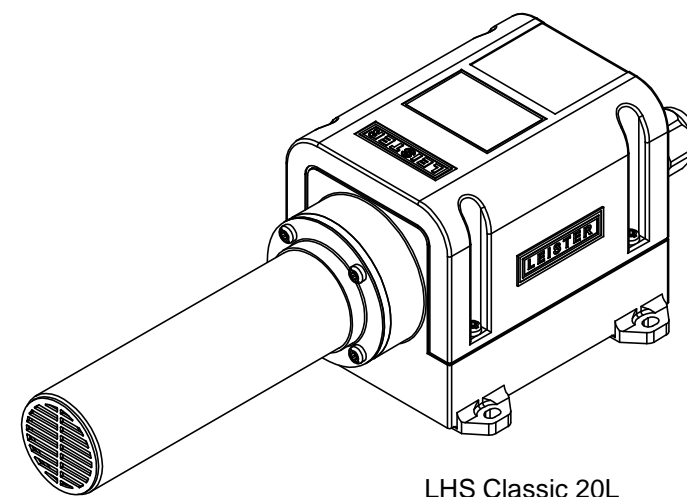
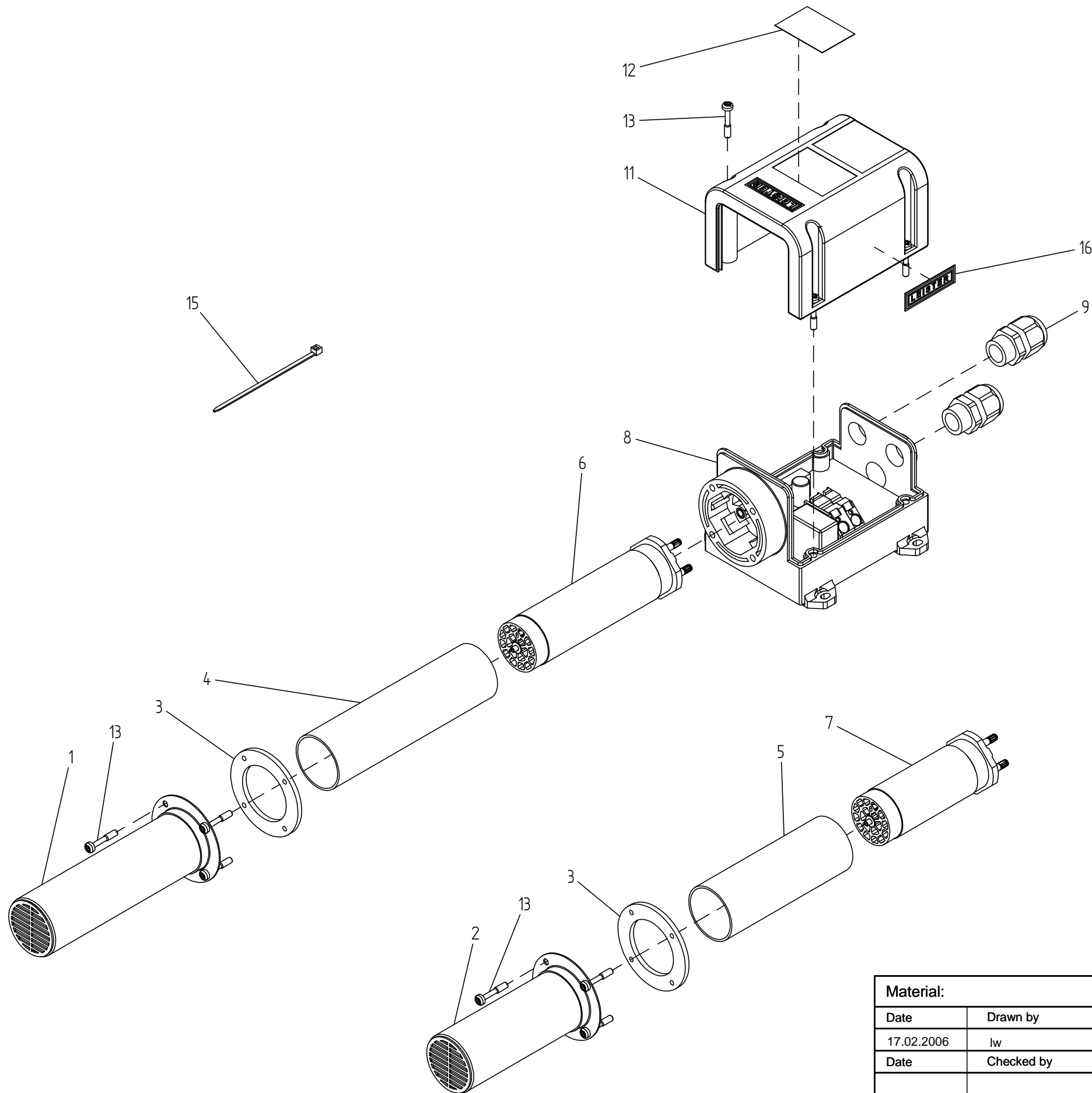

<b>Material:</b>				<b>Volume:</b>	
Date	Drawn by	<b>LHS Classic 20</b>			Sheet
17.02.2006	lw				1
Date	Checked by				of
			1	Revision	
LEISTER Process Technologies CH-6060 Sarnen		Format	Scale		Drawing number
		A3	%		020.103
					01

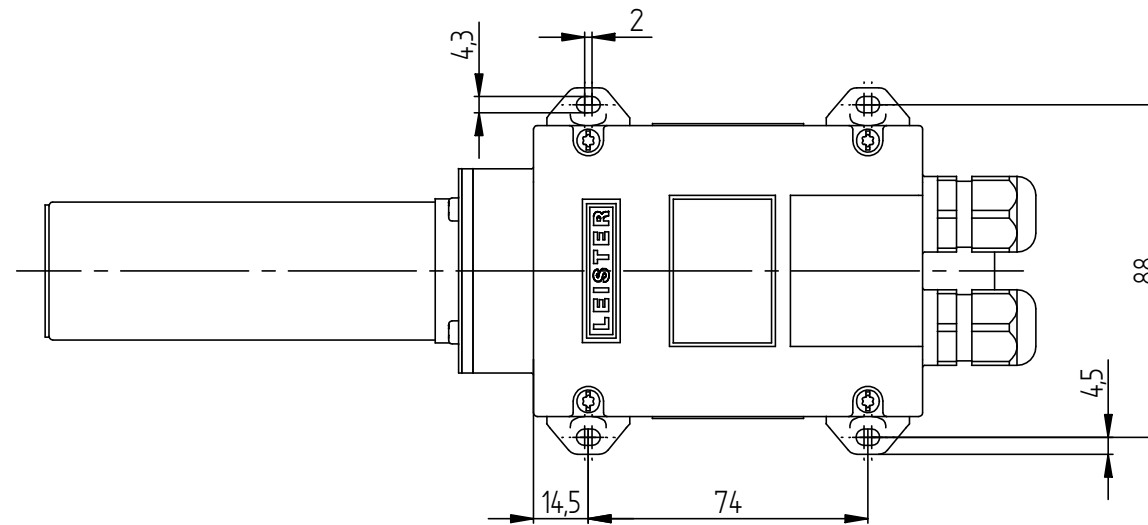
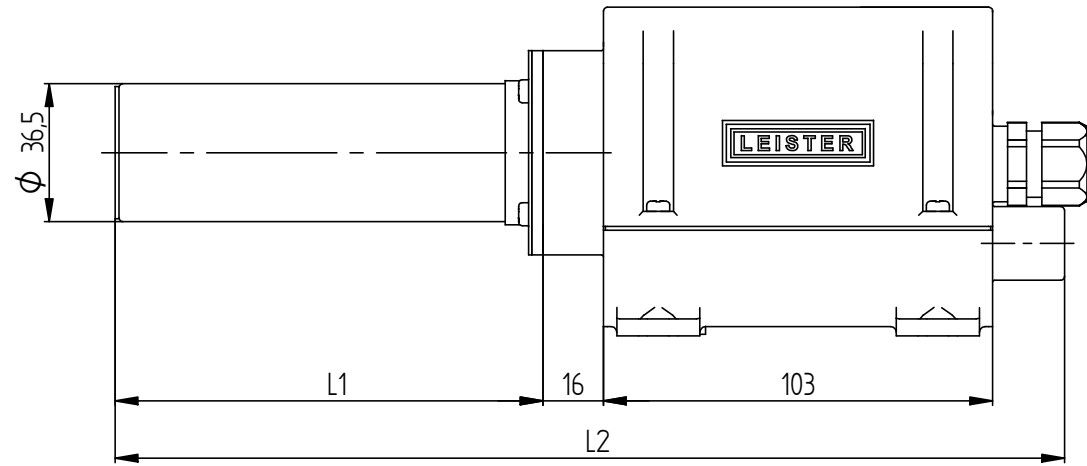
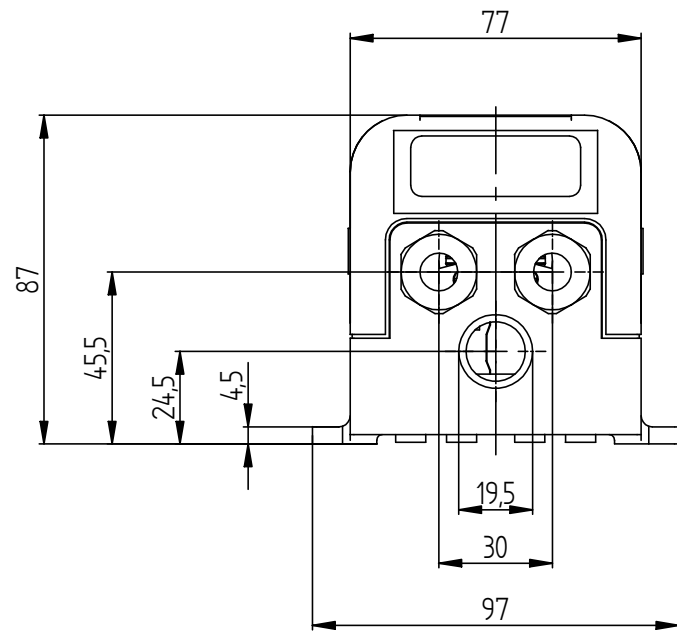

Typ	L1	L2
LHS Classic 20S	114	252
LHS Classic 20L	144	282

Subject to modifications

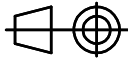
Werkstoff:				Volumen:		
Datum	Gezeichnet	LHS Classic 20			Blatt	
28.06.2004	lw				1	
Datum	Geprüft				von	
				1		
LEISTER Process Technologies CH-6060 Sarnen		Format	Massstab		Zeichnungs-Nr.	Index
		A3	1:2		020.008	01

A

B

C

D

E

F

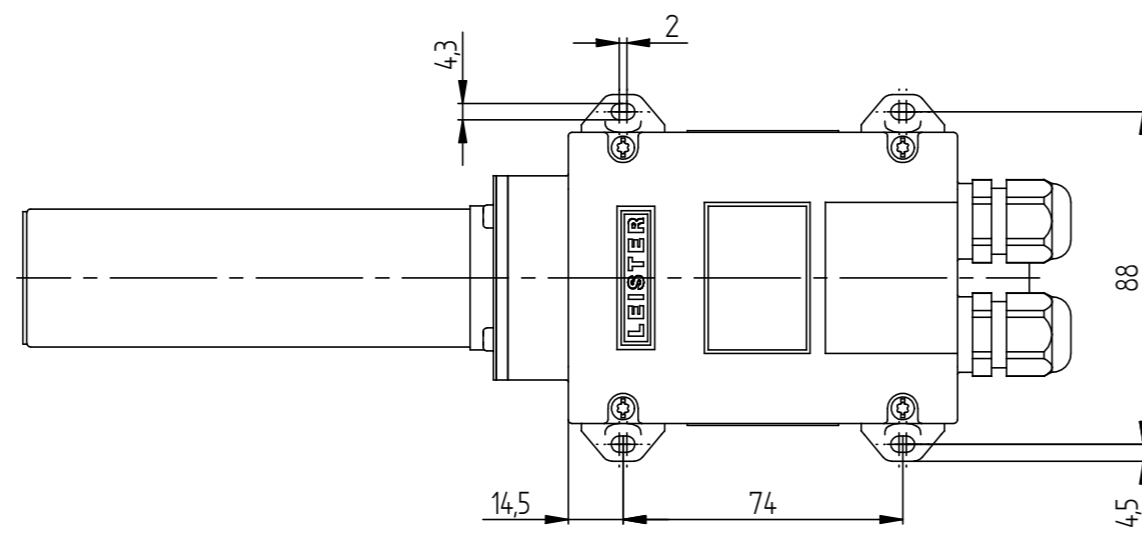
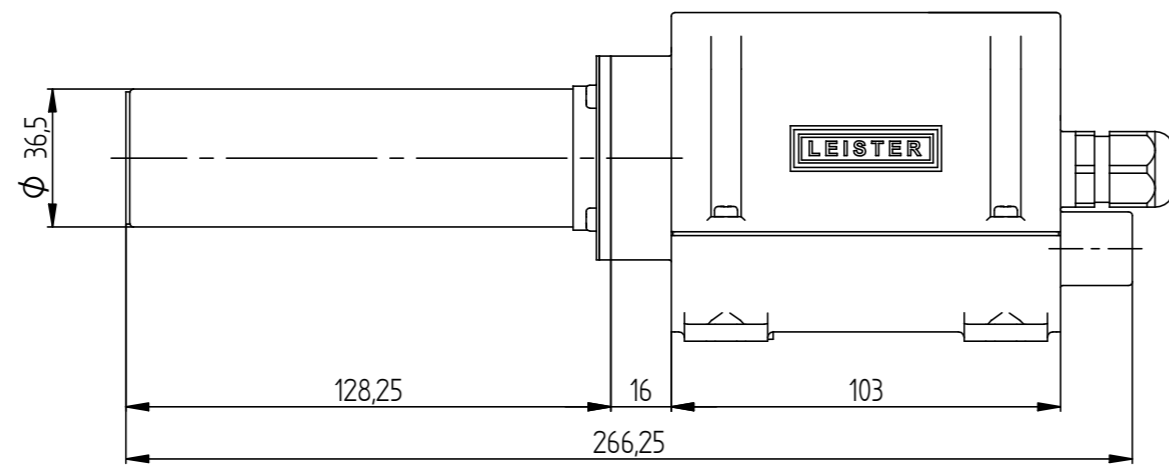
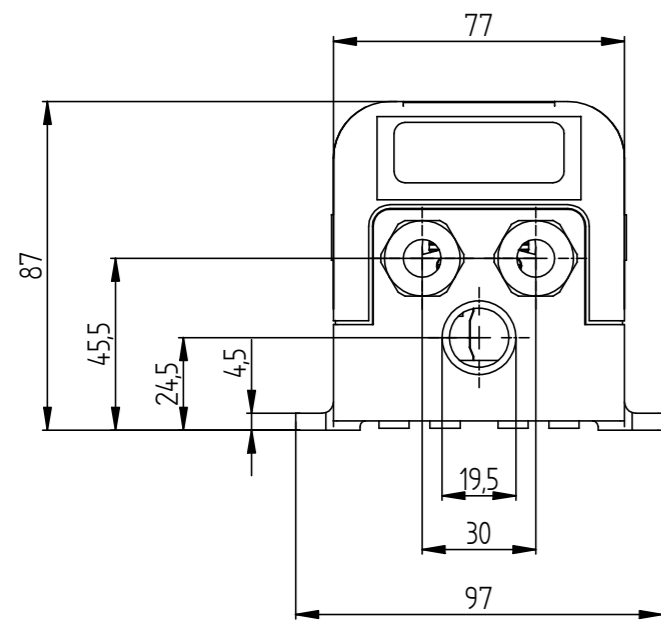

LHS Classic 20L

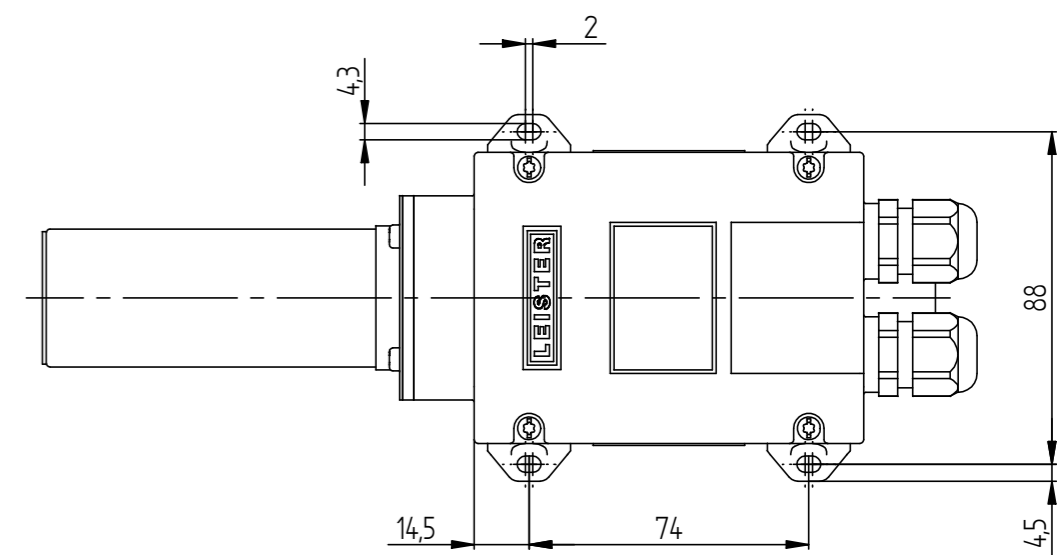
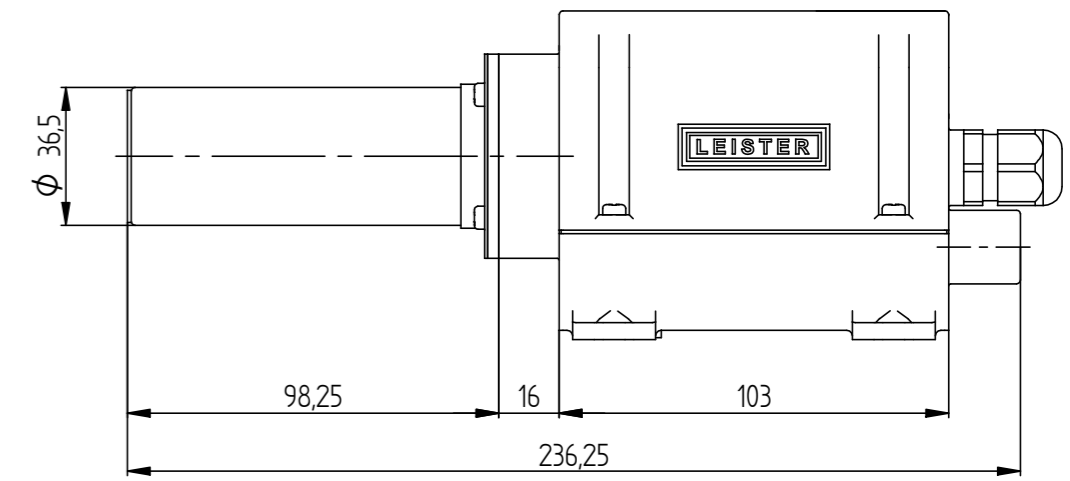
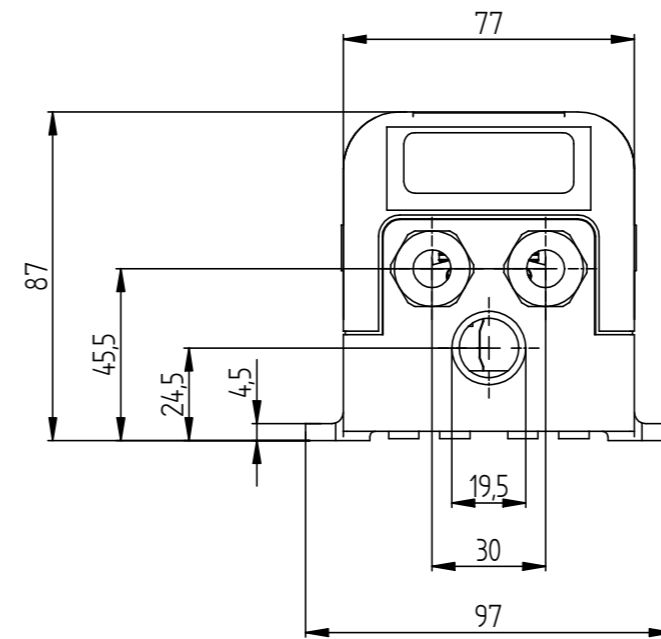

LHS Classic 20S

Subject to modifications

Material:				Volume:		
Date	Drawn by	LHS Classic 20			Sheet	
17.02.2006	lw				1	
Date	Checked by				of	
				1		
LEISTER Process Technologies CH-6060 Sarnen		Format	Scale		Drawing number	Revision
		A2	1:2		020.103	01

This document and the information in it contained are property of LEISTER and as such, they are to be considered reserved. Therefore, any reproduction in any form or by any means, without prior written permission of LEISTER is forbidden.