

LEISTER Uniplan E

Automatic hot air welding machine



Read the operating instructions carefully before use and keep for future reference.

APPLICATION

LEISTER Uniplan E Overlap Automatic Welding Machine

- Overlap and tape welding of coated fabric covers, foils and sealing membranes made of PVC-P, PE, ECB, CSPE, EPDM, PVDF etc. as well as PE coated tape fabric for lorries, tents, agricultural covers, building trade, biotopes, swimming pools, marquees, boat covers, inflatable boats, advertising hoardings etc.

Welding seam width 20 or 30 mm





WARNING



Danger! Unplug the tool before opening it, as live components and connections are exposed.



Incorrect use of hot air tools can present a **fire and explosion hazard**, particularly in the proximity of flammable materials and explosive gases.



Danger of getting burned! Do not touch the end of the heater tube and nozzle when they are hot. Let the tool cool down. Do not point the hot air flow in the direction of people or animals.



Connect tool to a **receptacle with protective earth terminal**. Any disconnection of the protective conductor in or outside the tool is dangerous!

Only use extension lead with protective conductor.



CAUTION



The **rated voltage** stated on the tool must correspond with the mains voltage.



For personal protection, we strongly recommend the tool to be connected to an **RCCB** (Residual Current Circuit Breaker) before using it on construction sites.



The tool must be operated **under supervision**. Heat can ignite flammable materials which are not in view.



Protect the tool **from damp and wet**.

Approval Marks



TECHNICAL DATA

Protection Class I



CCA certified

		230 ★	120 ★	100 ★
Voltage	V~	230 ★	120 ★	100 ★
Frequency	Hz	50 / 60	50 / 60	50 / 60
Power consumption	W	2300	1800	1500
Temperature	°C	20 – 620	20 – 620	20 – 620
Airflow (50-100%)	l/min.	max. 300	max. 250	max. 250
Drive speed	m/min.	1.0 – 7.5	1.0 – 7.5	1.0 – 7.5
Noise emission level	L _{pA} (dB)	67	65	65
Dimensions	mm	420×270×210	420×270×210	420×270×210
Weight	kg	11.5	11.5	11.5

★ Mains voltage is not reversible

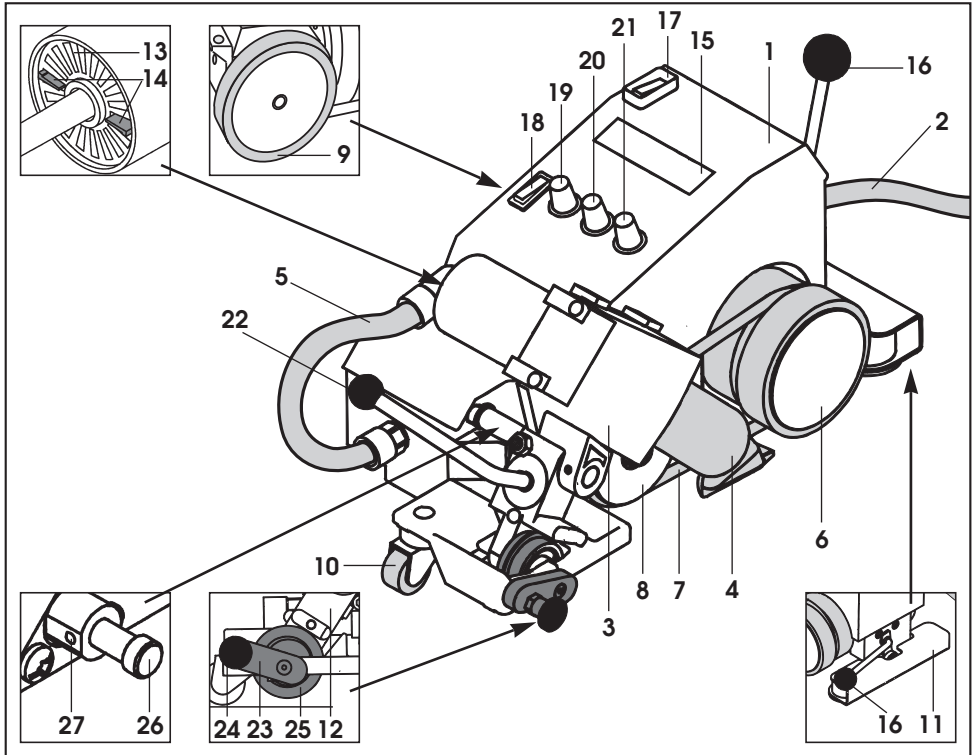

Main components

1. Housing/chassis
2. Mains cable
3. Hot air blower
4. Welding nozzle
5. Connection hose
6. Drive/pressure roller
7. Pressure belt
8. Guide roller
9. Drive roller
10. Steering roller
11. Lifting device
12. Support bracket
13. Air filter
14. Manual air vane
15. Display

Operating components

16. Lifting device lever
17. Main switch
18. Drive switch
19. Potentiometer for welding speed
20. Potentiometer for air flow
21. Potentiometer for air temperature
22. Swivel lever

Steering equipment

23. Guide roller lever
24. Guide roller knob
25. Guide roller

Automatic drive

26. Switch pin
27. Set screw

Operational condition

- Check the nozzle's basic setting. (Detail A)
- **Automatic drive**
Automatic drive is adjusted as required, depending on nozzle position by means of **switch pin (26)** and **set screw (27)**.
- **Guide roller**
According to the application, the **guide roller (25)** is set to "active" (operational) or "deactive" (non-operational) by means of **guide roller knob (24)** and **guide roller lever (23)** (see Details B and C). The **guide roller (25)** causes the automatic welding machine to carry out a straight run to the edge of the welding seam.
- Connect tool to the mains. Mains voltage must correspond with the voltage rating stated on the tool.
- Switch on tool using **main switch (17)**. **Hot air blower (3)** starts automatically.
- **Important: undervoltage**
In case the maximum temperature is not reached, reduce air volume by means of **manual air vane (14)** and **potentiometer for air flow (20)**.

Tool positioning

- Swivel **hot air blower (3)** using **swivel lever (22)** up to the stop.
- Operate **lifting device (11)** by means of **lifting device lever (16)** so that **drive/pressure roller (6)** and **drive roller (9)** are at no-load.
- If welding is being carried out by means of **guide roller (25)**, lock **guide roller lever (23)** into **support bracket (12)** (see Detail B).
- Position automatic welding machine into the overlap of the material to be welded. The outside edge of **drive/pressure roller (6)** and **guide roller (25)** must line up with the overlap edge of the material to be welded.
- Activate **lifting device (11)** by means of **lifting device lever (16)** so that the automatic welder is ready to start.

Detail A

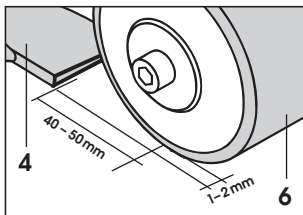

Detail B

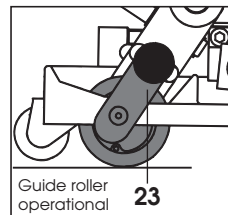

Detail C

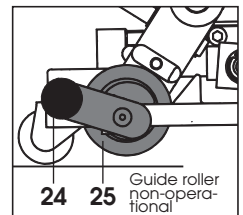

Welding parameters

- Set **potentiometer for welding speed (19)** to required value.
- Set **potentiometer for air flow (20)** to required value.
- Set **potentiometer for air temperature (21)** to required value.
- The pressure derives from the actual weight of the automatic hot air welding machine. Use additional weight if necessary.

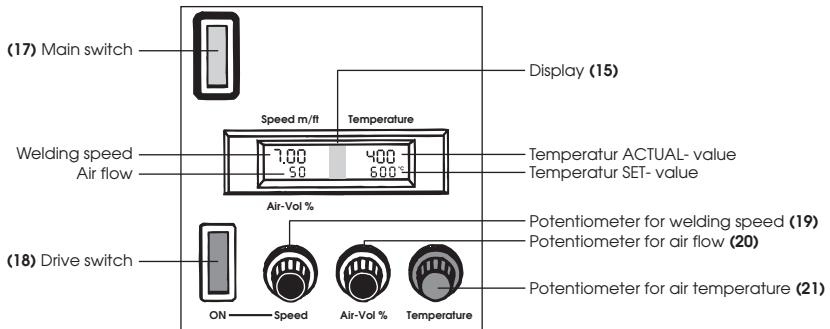

• Assembling additional weight

- Attach **additional weight holder (29)** to the Uniplan E tool by means of **cylindrical head screw M8x20 (28)**.
- Put **additional weight (30)** into **additional weight holder (29)**.

Accessory additional weight

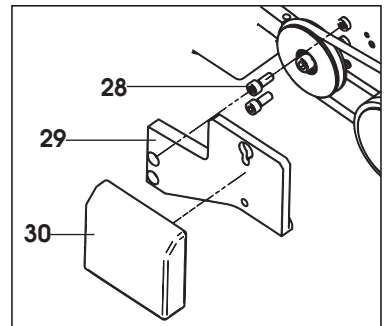

Welding process

- Swivel **hot air blower (3)** up to the stop using **swivel lever (22)**. The welding process starts automatically via automatic drive.
- If necessary, the tool can be started manually by means of the **drive switch (18)**.
- Check welding process. Adjust welding parameters using **potentiometers (19), (20)** and **(21)** if necessary.
- When welding has finished, swing **hot air blower (3)** to the stop by means of **swivel lever (22)**. Welding process stops automatically.
- After completing welding work, set **potentiometer for air temperature (21)** to zero so that the **hot air blower (3)** cools down.
- Switch off tool at the **main switch (17)**.
- Disconnect tool from the mains.

ACCESSORIES

- Only LEISTER accessories should be used.
- Additional weight with holder

TRAINING

- LEISTER Process Technologies and its authorised Service Centres offer free welding courses and training.

MAINTENANCE

- Clean the tool's **air filter (13)** with a brush when dirty.
- Clean **welding nozzle (4)** with wire brush.
- Check **mains cable (1)** and plug for electrical and mechanical damage.

SERVICE UND REPAIR

- Have your Service Centre check the motor brushes after about 1,000 hours of operation.
- Repairs should only be carried out by authorised **LEISTER Service Centres**. They guarantee a correct and reliable **repair service within 24 hours**, using original spare parts in accordance with the circuit diagrams and spare parts lists.

GUARANTEE AND LIABILITY

- Guarantee and liability are in accordance with the guarantee certificate as well as with the currently valid general business and sales conditions.
- LEISTER Process Technologies rejects any guarantee claims for tools which are not in their original condition. The tools must never be altered or changed.

Technical data and specifications are subject to change without prior notice.

Your authorized Service Centre is:



Service Record LEISTER Uniplan E

This document should be handed to the authorised LEISTER Service Centre for updating when repaired or serviced. This document is to be retained and kept by the owner of the tool.

Technical Data

Automatic hot air welding machine type

Order Number

Serial Number

Rated Voltage **V**

Rated Power **W**

Sold **Date**

Service

1. Date Service Centre Signature

2. Date Service Centre Signature

3. Date Service Centre Signature

4. Date Service Centre Signature

5. Date Service Centre Signature

6. Date Service Centre Signature

Repair

1. Date Service Centre Signature

2. Date Service Centre Signature

3. Date Service Centre Signature

