



PROCESS HEAT

TRIAC S ECONOMY ignition blower from Leister.

The built-in device for woodchip
and pellet heating systems.



Leister heats you up.

More and more house owners are choosing pellet and woodchip heaters. Independence from fluctuating oil prices and ecological principles are the key considerations in the choice of such heating systems. Leister supports this trend with its ignition blowers. Their reliability and stability make them the obvious choice for fully integrated use in pellet and woodchip heaters.

Ignition blower

TRIAC S ECONOMY

The most frequently used built-in device for pellet and woodchip heating systems.



Heating with wood – the right approach

- CO₂ neutral: The same amount of CO₂ is released on burning as the wood has absorbed during its growth
- Shorter transport routes
- Regional resources are used and your local suppliers supported as a result
- No dependence on fluctuations in the price of oil
- Long-term assured fuel supply

TRIAC S ECONOMY ignition blower

- Built-in device for fast and safe ignition
- Operational safety thanks to electronic protection of the heating element
- Blower and heating element can be controlled separately
- Fulfils Flicker Standards and RoHS Directives

Technical Data

Voltage	V~	230	230
Power	W	1600	1000
Frequency	Hz	50 / 60	
Temperature max.	°C	600	
Airflow rate (20°C)	l/min	230	
Static pressure	Pa	ca. 3000 (30 mbar)	
Noise level L _{pA}	dB	65	
Weight	kg	1.3	
Conformity symbol		CE	
Protection class II		□	
Connection lead		silicone, 3 × 1 mm ² x 2 m	

Article numbers

Art. 124.918	TRIAC S ECONOMY 1600 W ignition blower
Art. 122.501	TRIAC S ECONOMY 1000 W ignition blower
Art. 123.585	Connection adapter for air hose, 38 mm (not included in scope of delivery)
Art. 107.286	Air hose
Art. 107.287	Hose clip

TRIAC S ECONOMY
dimensions

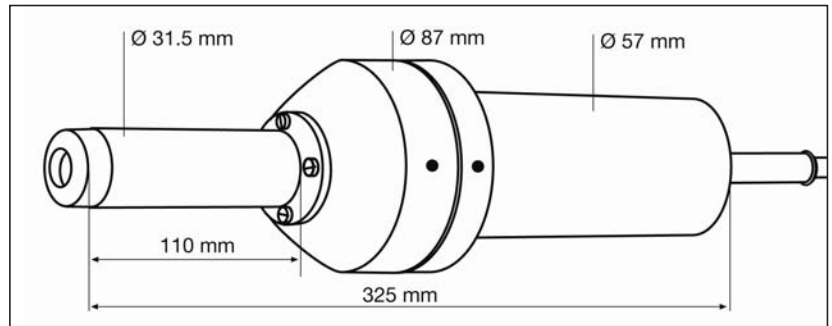

Pellet / woodchip boiler principle

- 1 Pellet / woodchip silo
- 2 TRIAC S ECONOMY ignition blower
- 3 Combustion chamber
- 4 Heat exchanger

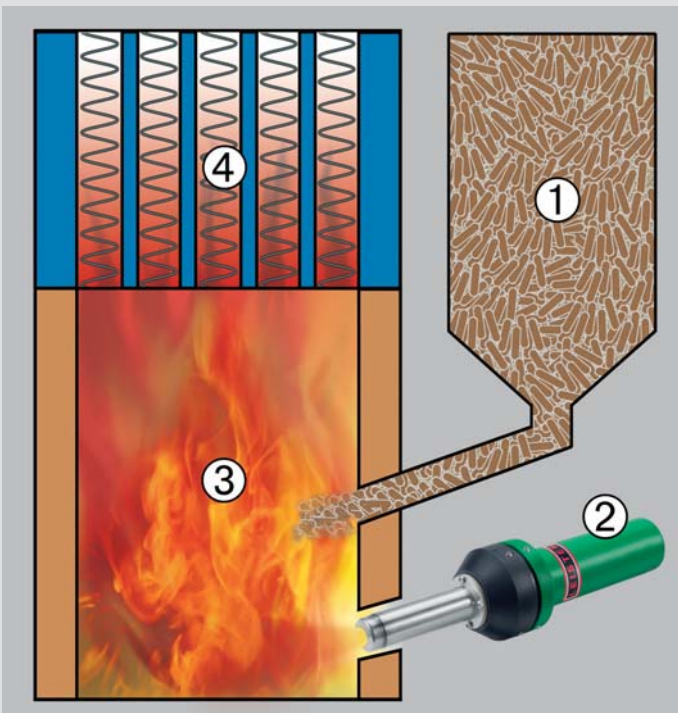

Accessories:

Connection adapter for air hose
(not included in scope of delivery)



Leister every time.

Besides the TRIAC S ECONOMY, there are other device types available depending on your space and power requirements.



ELECTRON – the most powerful in the team.

This powerful ignition device has no respect even from damp burning material.

Art. 123.917



MISTRAL – the long-distance runner.

It may sometimes be necessary for wooden based materials to be dried. MISTRAL accomplishes this task with ease.

On request



HOT JET S – small and smart.

Fits also in small house heaters. Thanks to its quite performance, the harmony is not disturbed.

On request



Headquarters:

Leister Process Technologies
Galileo-Strasse 10
6056 Kaegiswil/Switzerland

phone: +41 41 662 74 74
fax: +41 41 662 74 16
leister@leister.com

www.leister.com

Leister Process Technologies is an **ISO 9001:2000** certified enterprise.

Specifications are subject to change without prior notice



Our close worldwide network of more than 120 Sales and Service Centres in more than 60 countries.

© Copyright by Leister